

STAPLELOK[®]

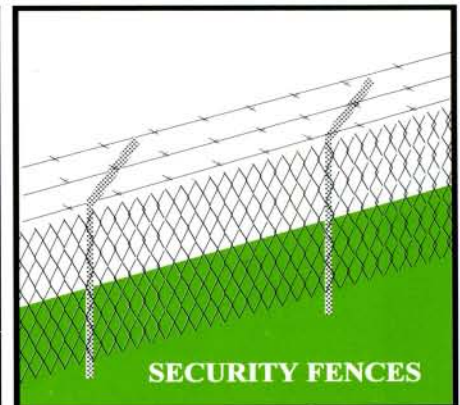
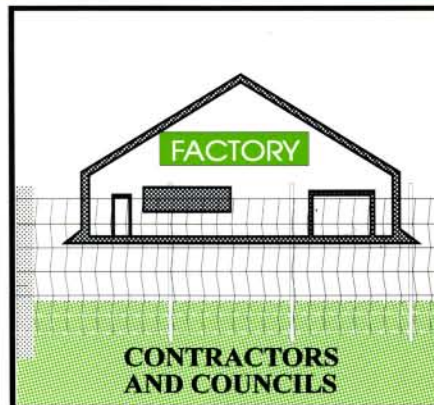
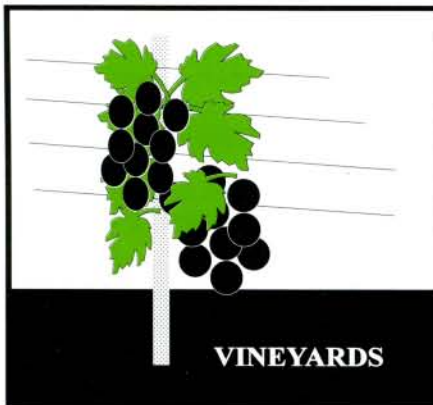
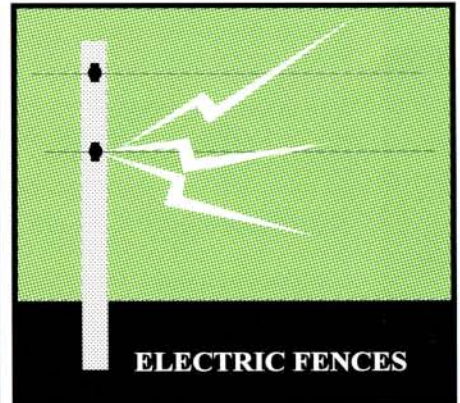
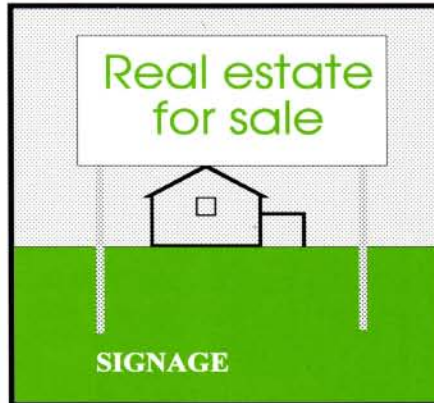
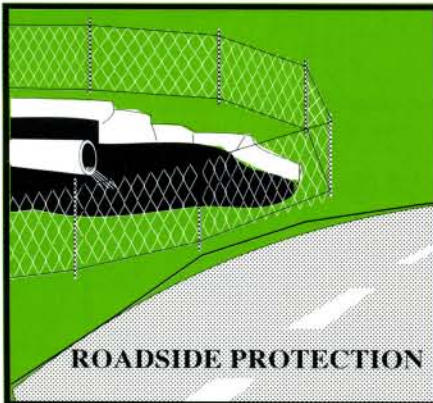
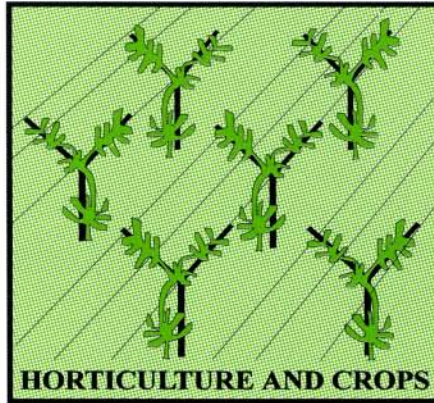
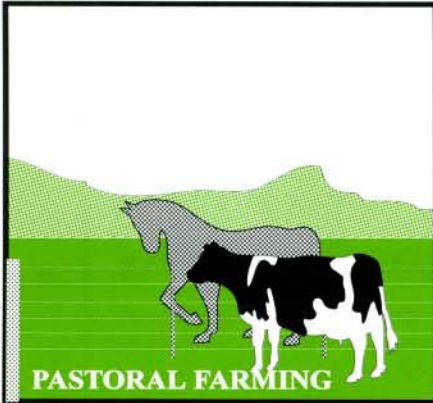
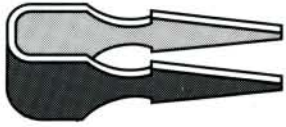

THE UNIQUE FENCING AND
CONSTRUCTION SYSTEM

STAPLELOK... USED AROUND THE WORLD

Why?

- * 75% Installation savings
- * High tensile steel posts
- * Galvanised coating
- * Any wire type, any spacing
- * Easy to carry and erect

Staplelok works because the patented steel post snaps around the staple locking it firmly in place.

The strong high tensile steel post survives all fencing applications

The wire slides freely through the staple allowing continual tensioning and retensioning

Staples are hammered home with a couple of taps of a hammer. Any number of staples can be fixed anywhere up or down the post

There is no wire tying, the wires are run out in the usual way and then stapled home

All posts are zinc galvanised for long life

Staplelok posts are easy to carry. This is a major time and money saver when laying out or carting materials to remote locations.

Posts are easily removed with the Staplelok post jack

Staplelok posts are easily driven using the Staplelok "Thumper" a double impact hand driver

Any wire - line wire, netting, chain link, etc. can be used at any gauge spacing

Staplelok posts can be easily footed with the Staplelok auger bit and handle. They can also be used for wire stays

The Staplelok post's scalloped groove stops the staple riding up or down the post

Insulators can be fixed with screws or staples in the conventional way for electric fencing

Strengthened tips for straight driving in the stoniest ground

This section view of a Staplelok post shows how the staple is locked in place after being hammered home

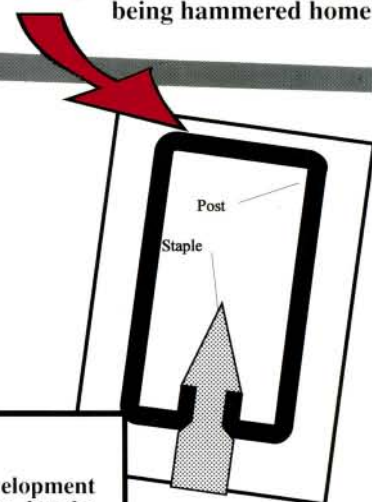
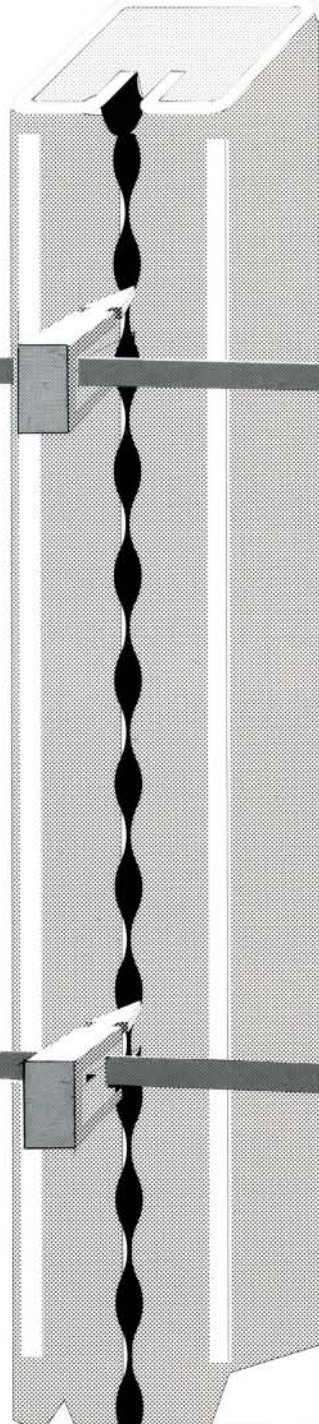

Your Guarantee of Quality

The product you receive is the result of extensive research and development involving field testing, strength and structural design advice given by the Department of Civil Engineering, University of Auckland. Staplelok guarantees that its products are free from defects in respect of material and workmanship at the date of delivery and will repair, replace or refund the purchase price of the faulty product at its option.



INSTALLATION... SOME SIMPLE TIPS

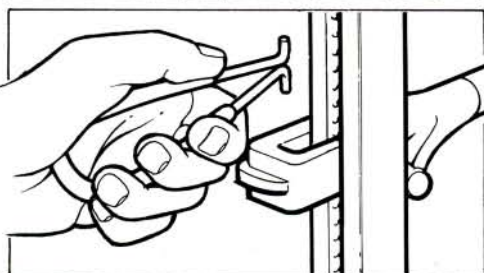
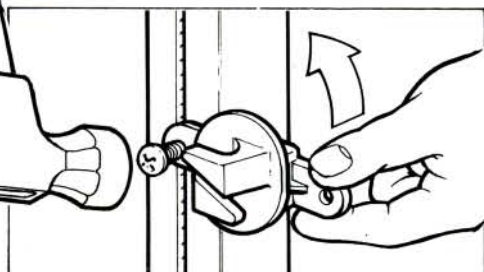
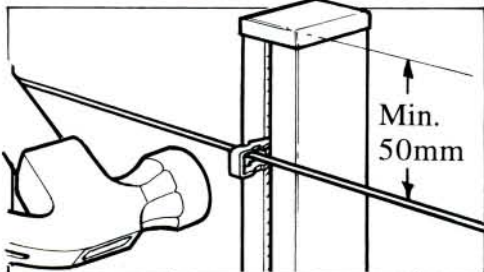
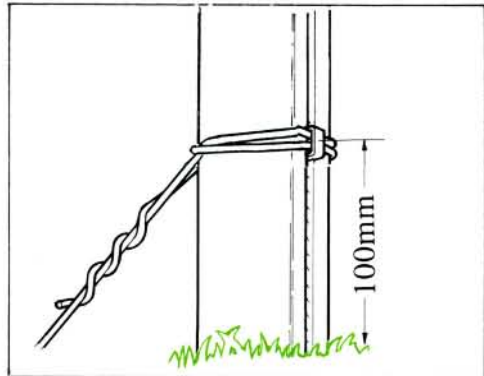
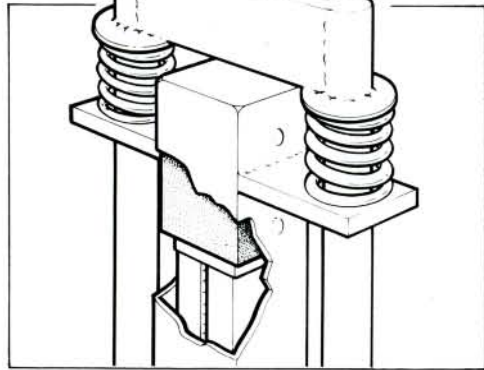
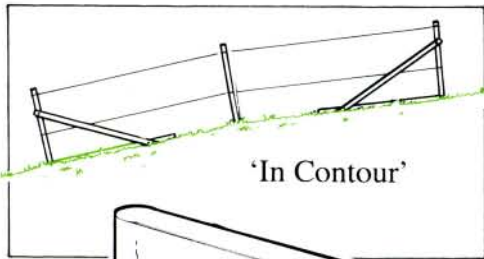

STRAINERS, ANGLES, HUMPS AND HOLLOW

When installing strainers and posts make sure they are perpendicular to the slope of the land, i.e. 'in contour' as in the diagram. Strainer assemblies or wire tie backs using the auger bit can be used at angles in the fence line, but ensure the stay of the assembly bisects the angle exactly in half. When installing posts at humps or hollows, make sure that the gap between the top of the post and a line drawn between the tops of the two adjacent posts is no greater than one metre. Otherwise too much upwards lift or downwards pressure will occur. Additional posts should be installed to split the angle and spread the load.

THUMPING OF POSTS

Before unbundling posts, mark both ends and flat sides of bundle at height post required out of the ground. If possible, allow 50mm of post above top wire for easy entry of staple into groove. Then thump post into ground to the bottom mark. Note thumper has large plug of steel inside so post does not go right to top of thumper. Thump post with post cap on. Use two guide wires between strainers to give a straight line. Ram posts in contour with land i.e. at 90 degrees to the guide wires. Stand sideways to the fence line and lean body against guide wires to keep them out of the way while thumping.

FOOTING OF POSTS

Stainless steel wire is best to use with auger bits as it will last longer in the ground. Always 'foot' strainer posts and posts in dips and gullies with an auger bit. Corkscrew straight down into the ground, 200mm away from the back of the post. Pull wire through ground as much as possible and tie off about 100mm up the post as in the diagram. Slide up the post and insert staple. Auger bits will hold up to 500kg in hard clays and clay gravel mixtures. Refer to technical pamphlet. Not suitable for swampy ground, loose topsoil or stoney soils. In this case, use a post driven into the ground at an angle and wire together.

QUICK AND EASY STAPLING

If wire is required to be stapled higher than 50mm below top of post then flick cap off with claw of hammer. (Cap does not allow post to expand and let staple in.) Staple can now be hammered in. Cap can be repositioned by squeezing top of post with vice grips and tapping back on. When stapling posts at the top of a rise, staple wires from the bottom up. When stapling in a dip, staple wires from the top down. When tensioning wires with Magic Mushrooms, lock into one slot on the hub only.

FIXING INSULATORS AND OUTRIGGERS

Standard insulators can be fixed to the post using staples or screws. Hit them in with a hammer, as groove cannot be prised open while screwing. Put screws into insulator holes, hold sideways to post, and hit screw in. Feed wire through the insulator, turn upwards, and hit other screw into groove. Use Post Opening Tool to open groove to insert end insulator clip. Simply squeeze prongs together, insert and release. The 300mm Outriggers are similarly installed, but spread the legs to give them greater stability. Fit Outrigger Clips to run multiple electric wires.



Handle
(WSCH)



Magic Mushroom
Wire Strainer
(WSCB, WSCBO)

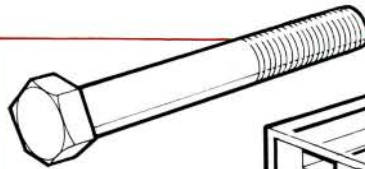

Right Angle Joiner
(RAJ)
Either nut or bolt head
can be inserted inside

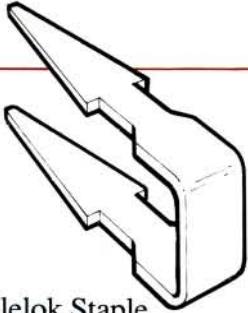
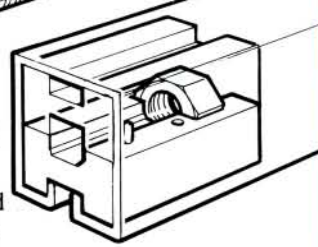

Staplelok Staple
(ST200, ST1000)

Deer/Ostrich

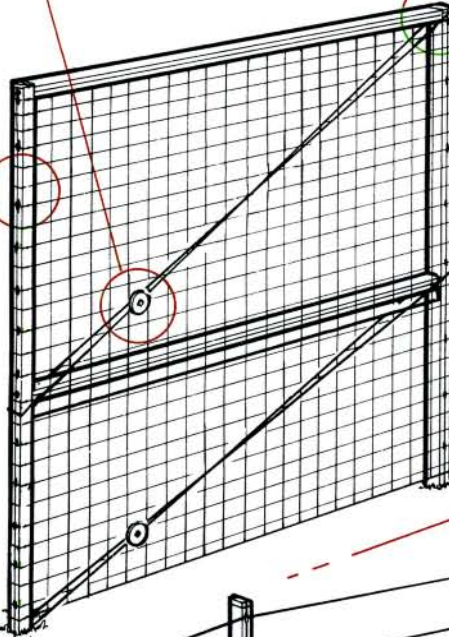

Staplelok Post Cap
(CAP)

Max. 1m

Line Wire

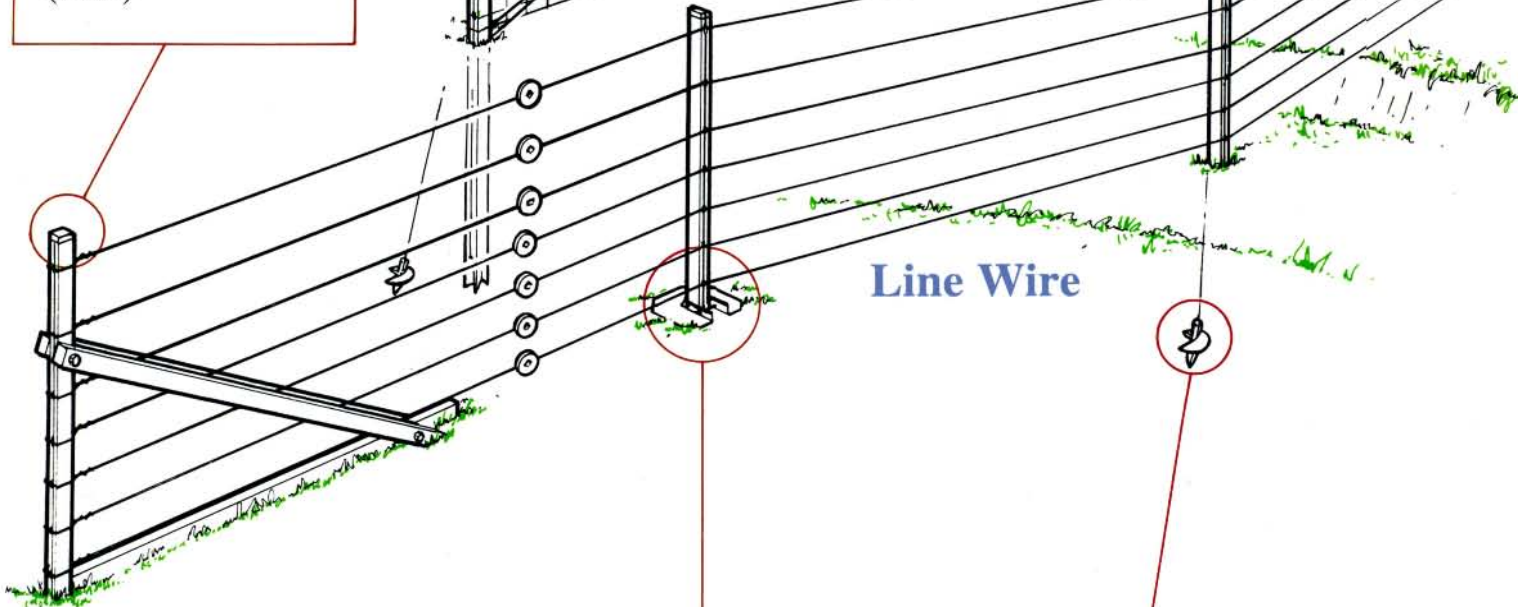

Crushed Tip
Fluted fins ensure
straight driving

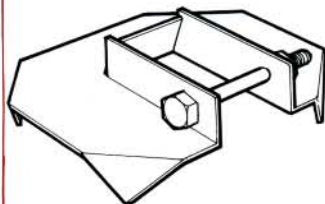

Staplelok Anti-Sink Plate
(ASP)

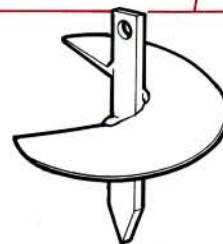

Staplelok Auger Bit
(AB, ABB)

Droploc
(DL3,5,

Droploc
(DLAC,

Droploc
Fastenin
(DLCFT

HEART OF THE PLELOK® ING SYSTEM

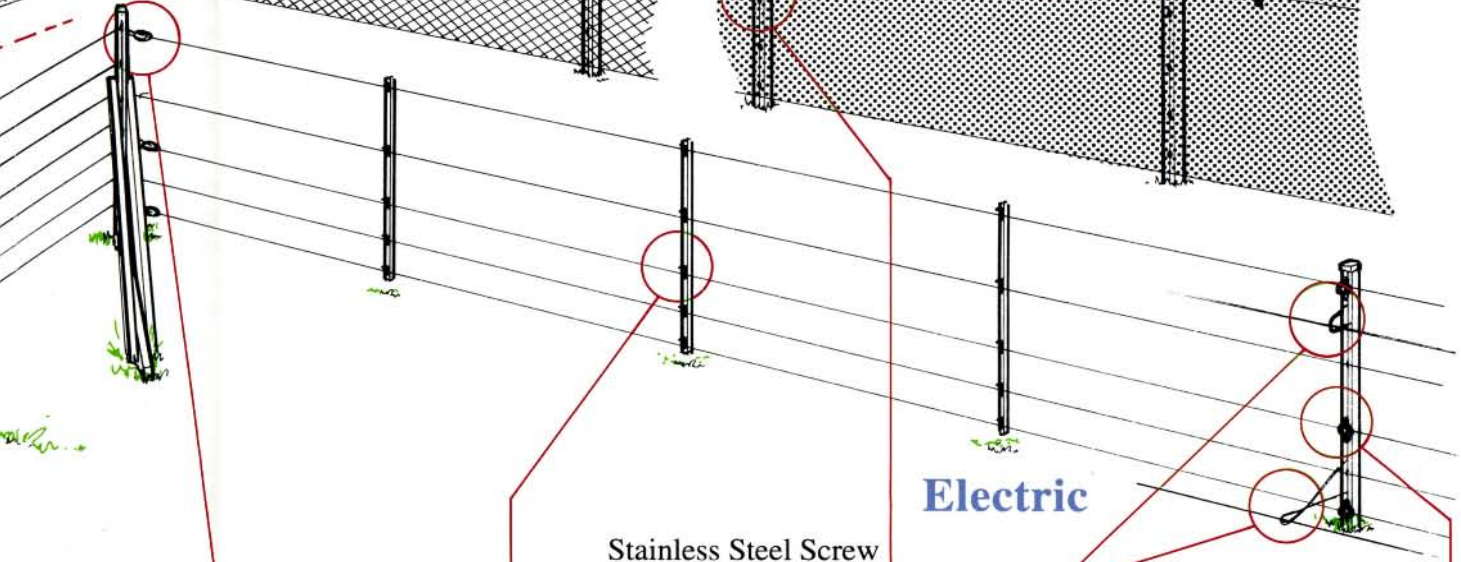
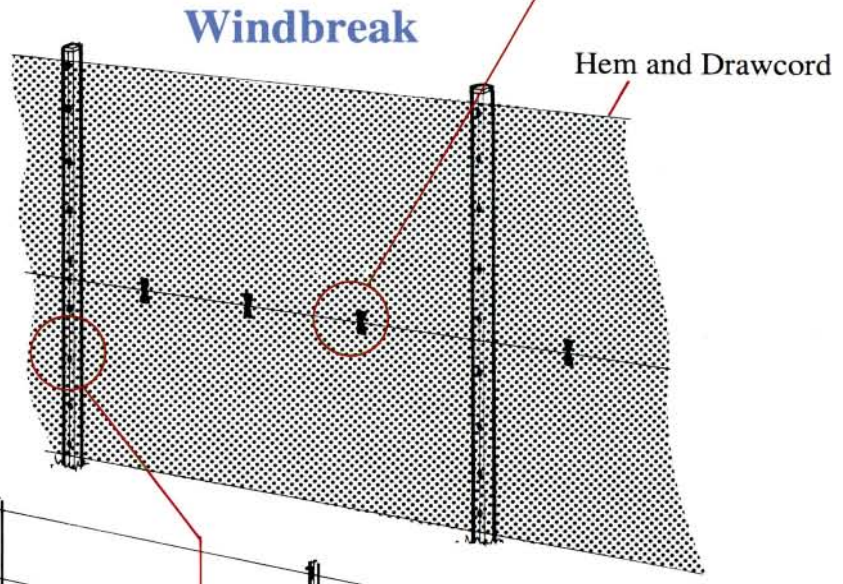
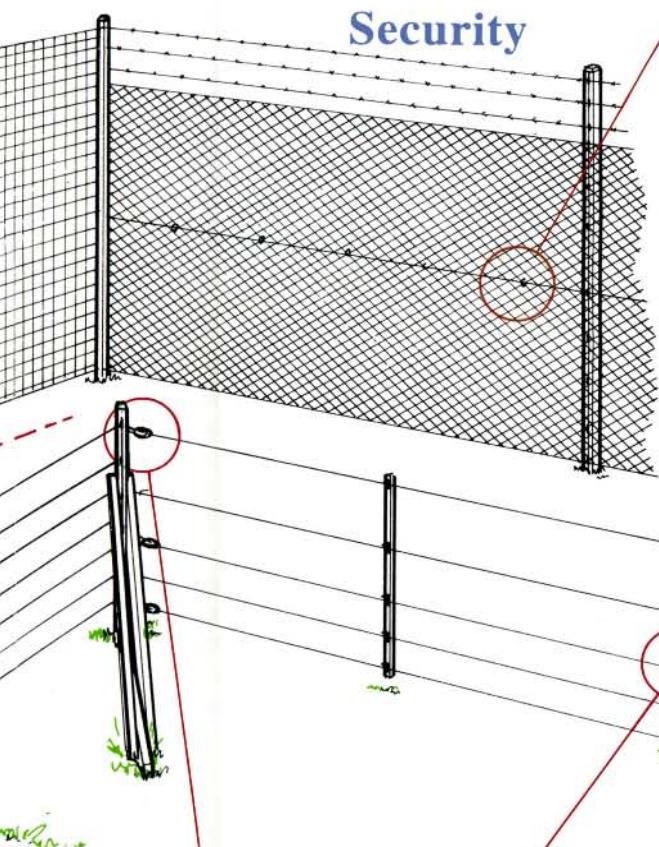
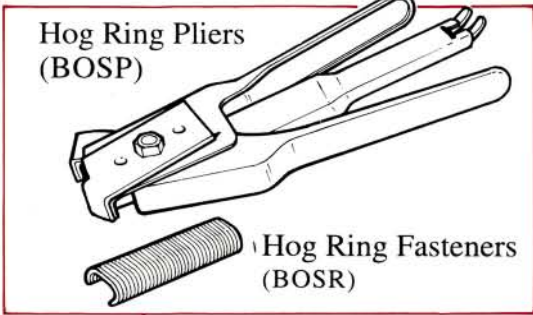

Stainless Steel Screw
8g 25mm
(SSC200, SSC1000)

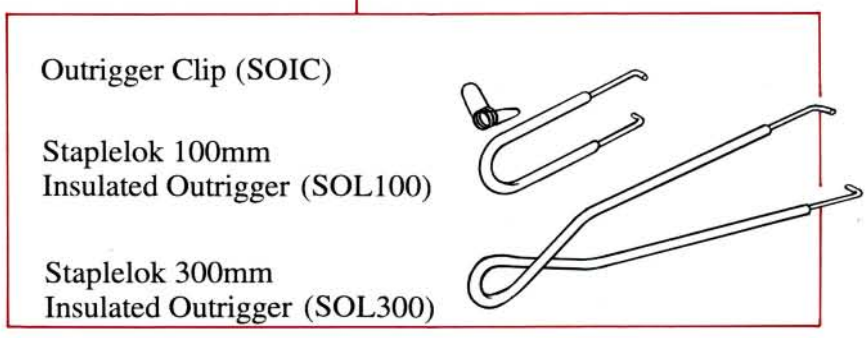
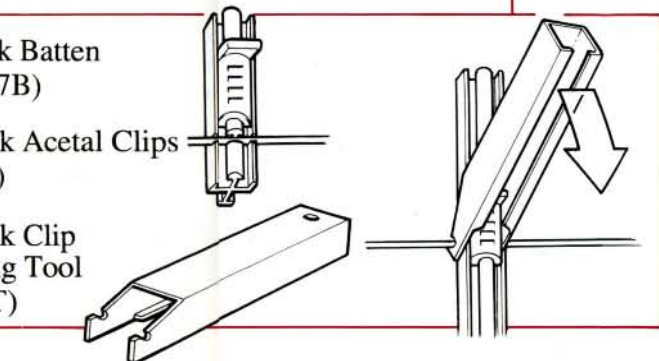
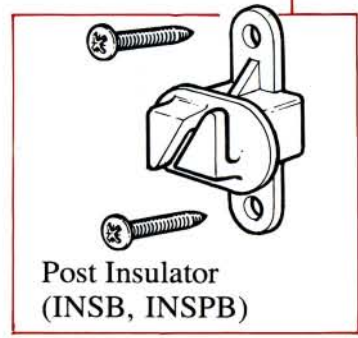
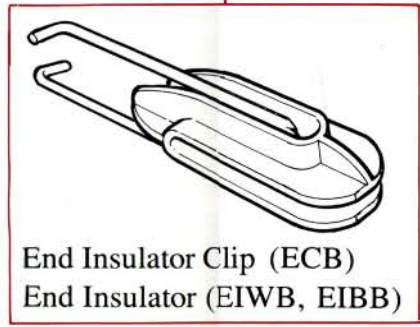

STRAINERS AND BATTENS... THE EASY WAY

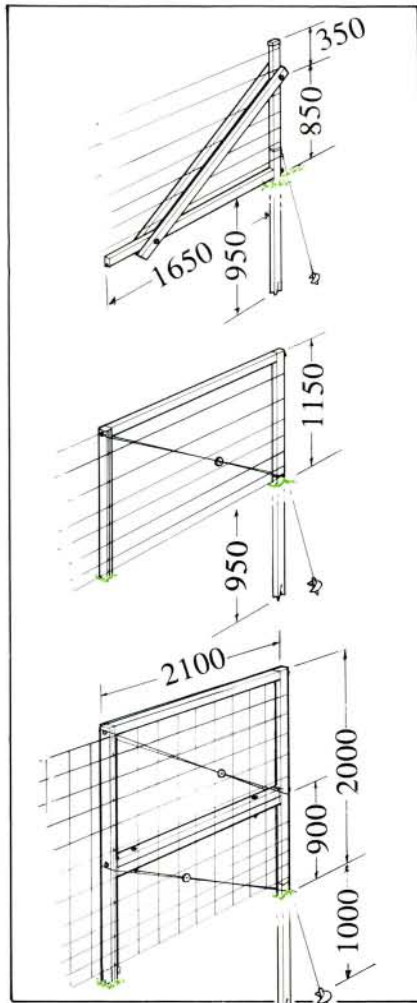

STAPLELOK STRAINER SYSTEMS

All Staplelok Strainer Systems are sold as a complete assembly, including bolts, stays and right angle joiners. Simply thump the strainer post into the ground, bolt and diagonally wire together. Ensure the strainer post is 'footed' with the auger bit. Refer to individual pamphlets for technical details on each assembly.

1. Stayed Strainer Assembly

Suitable for line wire fences. Can also be used at an angle in the fence line. Ensure the stay evenly bisects the angle. The assembly will take a full 7 wire strain at 150kgf per wire. Refer to technical pamphlet. If using electric wires, insert end insulator clips and terminating end insulators into the strainer post groove and use 30mm polythene pipe between the assembly stays to protect electric wires from shorting. Use a base plate under assembly toe in soft soils to prevent sinking.

2. Single Box Strainer Assembly

Suitable for 1.2m fabricated field fence, chain mesh and windbreak cloth. Use a diagonal loop of 2.5mm HT wire in the box and tension with the Magic Mushroom Wire Strainer.

3. Double Box Strainer Assembly

Suitable for deer and ostrich netting, taller chain mesh and windbreak cloth. Will accept a 13 wire deer netting strain, tensioned to 75kgf on each wire. Use an anti sink plate on front post. Use 2.5mm HT wire in boxes ensuring the lower diagonal brace wire is wrapped twice around the post and at least three times around itself.

DROPLOCK BATTENS

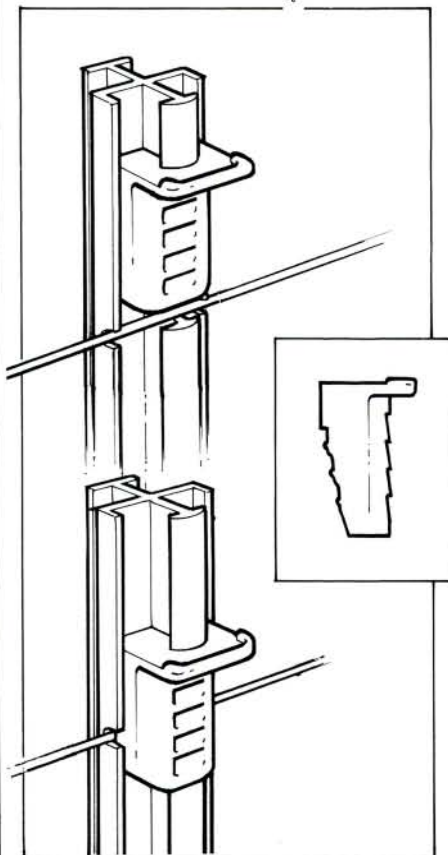

The patented Droplock™ battens are fully insulated, easy to install and suitable for all electric fencing up to 2.5mm wire. They are made from PVC (the same as the road markers) and are UV resistant for a long life. Besides keeping the line wires at their correct spacings, the white Droplock battens and red acetal clips are so highly visible that posts can be spaced further apart, whilst still retaining that visual barrier. They are fire retarded, of light weight and non abrasive, therefore preventing corrosion of the wire and extending the life of the fence. Droplock battens with an aluminium 'hot strip' conduct electricity to all wires and avoid the need to use wire and joint clamps. There is no stapling or wire fastening required, resulting in considerable labour savings. The clip is initially pushed down with the thumb and then locked tightly with the Droplock Clip Fastening Tool. The louvres at the front of the clip stop it slipping back up the batten. Various sizes of battens are available with preset wire spacings. Because the batten is fully insulated, both dead wires and electric wires can be run along the fence. When used in conjunction with Staplelok posts, and the energiser earth terminal is connected to a dead wire on the fence, every Staplelok post becomes an earth post, giving a very highly effective earthing system right around the farm.



STRONG AND LONGLASTING

Staplelok posts are very strong. They are made to exacting specifications from high tensile steel and meet the toughest criteria. They are zinc galvanised for long life. The strengthened closed tip of the post enables straight driving in the stoniest ground.

The unique staple is manufactured from high tensile steel and once driven into the post with the tap of a hammer, locks permanently in place. Extensive use and factory testing of the Staplelok system has proven that the staple will not slip up or down nor will it pull out.

SPEED AND VERSATILITY OF INSTALLATION

Fencing takes time and time is money. The Staplelok system is much faster to erect per metre than timber or other steel posts due to its unique method of attaching the wires to the posts and driving them into the ground. No holes to line up, no leading edges to rub the galvanising off the wire, no tying on and no holes to dig. When the wire is strained it can be stapled anywhere up and down the post. Any wire spacing, any type of wire.

ENVIRONMENTALLY FRIENDLY

Consumer markets around the world are concerned about the leaching of poisons from treated timber. Not with Staplelok though! Clean non poisonous posts means clean soil. Staplelok posts are fully recyclable.

EASY TO HANDLE

Staplelok posts are conveniently strapped into bundles of ten, making them easy to shoulder and carry in even the toughest and most rugged country.

SAVE 75% OF INSTALLATION COSTS

Competitive pricing is the Staplelok way. Fencing is all about costs per metre and the time it takes to do it. Tests undertaken by the Hamilton Agricultural Engineering Institute proved that the Staplelok system can be installed 75% cheaper than hydraulically driven wooden posts. All posts were driven to master fencer tolerances.

A guide to post sizes

Post Size	Type of application
1.37	Domestic garden, tie down, earthing electrical systems, fencing against small animals. Horticulture outriggers.
1.50	Electric Fencing in hard ground for all stock
1.65	Hard ground, sheep and cattle, sign posting, goats and pigs, shrub protection.
1.80	Soft ground, sheep and cattle, goats and pigs.
2.40	Security fencing, very soft sheep and cattle country, horticulture, bulls, horses.
2.70	Deer fencing in snow free country, footing in soft or swampy ground, security.
3.00	Deer fencing in snow country, ostriches.

A guide to post spacing on flat land

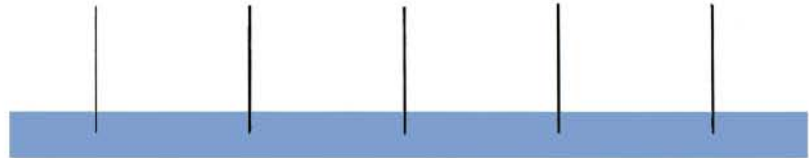

Heavy Duty Fence

Bulls, wild pigs, kangaroos, large wild animals, Staplelok posts
2 metres apart with line wire, 4 metres with battens or netting

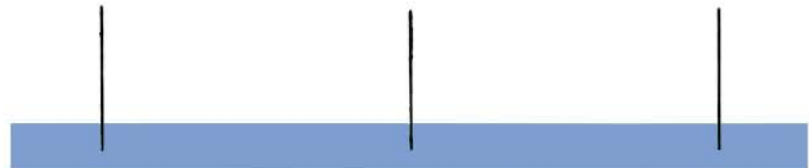

Cattle Fence

Staplelok posts 4 metres apart with line wire, 6 metres with battens or netting



Deer Fence

Staplelok posts 6 metres apart with netting.



Sheep and Goat Fence

Staplelok posts 3 metres apart with line wire, 5 metres with battens or netting.

Staplelok Fencing Tools and Accessories



Wire Care Vineyard clips for quick release of wires. Can also be fixed to back of post with Tek screw.

Simply hit high tensile steel staples with hammer.

For electric fencing, fix insulators by hitting in galvanised screws with hammer.

Use stainless steel insulator clips for high strain end insulators, open post groove with screwdriver, squeeze clip together, insert and release.

The Staplelok Post Cap Protector is used when a thumper can't be, such as for footing and stay posts. Don't hit the posts directly with a sledge hammer because this will damage the staple fixing mechanism.



The Staplelok Post Lifting Jack easily removes the posts from the ground, simply place the post between the jaws and stand on the step.

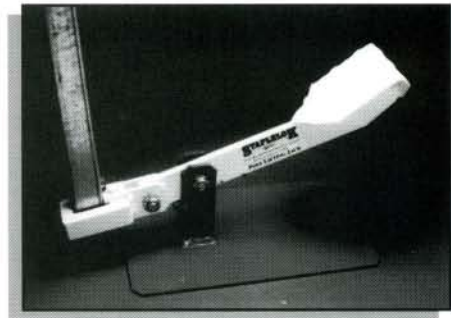

The Staplelok Auger Bits and handle are used for footing posts and anchoring wire tie backs. Feed wire up through handle, corkscrew into ground and then remove handle.



The Staplelok startup kit includes a strong toolbox, thumper, post jack, post cap protector, staples, screws, end insulator clips, wire strainers and handle, auger bits and handle and right angle joiners giving a complete startup package for users of the Staplelok system



The Staplelok "Magic Mushroom" permanent in line wire strainer. Insert wire into slotted hub, turn with Staplelok T handle to required tension and engage wire into one locking slot only.

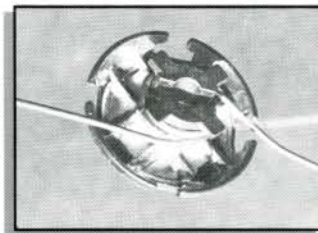

Your Local Distributor:



dberr Ltd
Staplelok Fencing

Director - Duncan Berry
Sales - Simon Harvey

Tel: +44 (0) 1684 854499

Fax: +44 (0) 1684 354445

Email: duncan.berry@dberrimpexp.co.uk

Email: simon.harvey@dberrimpexp.co.uk

Web: www.dberrfencing.co.uk